

# 3M™ Super Close Projection SCP715/717/740

## 3M™ Digital Media Systems DMS700 Series

### Troubleshooting Guide



SCP715



SCP717/SCP740



DMS700



Use this guide to determine if your unit requires repair service.

## Table of Contents

<b>No Power .....</b>	<b>3</b>
<b>Lamp Will Not Ignite .....</b>	<b>4</b>
<b>Lamp Will Not Remain Lit.....</b>	<b>5</b>
<b>Poor Video Image (Composite or S-video) .....</b>	<b>6</b>
<b>Poor Graphical Image (VGA or Component).....</b>	<b>7</b>
<b>Poor Sound .....</b>	<b>8</b>
<b>Digital Annotation Issues .....</b>	<b>9</b>
<b>Maintenance Procedures.....</b>	<b>Error! Bookmark not defined.</b>
<b>Additional Information .....</b>	<b>10</b>

The 3M logo and 3M are trademarks of the 3M Company. Other trademarks used herein are the properties of their respective owners.

### **Important Notice**

All statements, technical information, and recommendations related to 3M's products are based on information believed to be reliable, but the accuracy or completeness is not guaranteed. Before using this product, you must evaluate it and determine if it is suitable for your intended application. You assume all risks and liability associated with such use. Any statements related to the product which are not contained in 3M's current publications, or any contrary statements contained on your purchase order shall have no force or effect unless expressly agreed upon, in writing, by an authorized officer of 3M.

### **Warranty and Limited Remedy**

3M warrants that when the 3M Product is used according to 3M's Intended Use Statement ([www.3M.com/meetings](http://www.3M.com/meetings)), it will perform satisfactorily for the warranted durability period as stated in the applicable 3M Product Manual in effect at the time of purchase. The warranties stated in the applicable 3M Product Manuals are exclusive and are made in place of any and all express or implied warranties or conditions, including any implied warranty of merchantability or fitness for a particular purpose, or any industry practice or custom or trade usage. Failure to follow the instructions contained in the appropriate 3M Product Manual or to use the 3M Product in accordance with 3M's Intended Use Statement will void all warranties and limited remedies.

**EXCEPT AS SPECIFICALLY STATED IN THE APPLICABLE 3M PRODUCT MANUAL, 3M SHALL NOT BE LIABLE FOR ANY INDIRECT, INCIDENTAL, SPECIAL OR CONSEQUENTIAL DAMAGES (INCLUDING, BUT NOT LIMITED TO, LOSS OF PROFITS, REVENUE OR BUSINESS) RESULTING FROM, OR IN ANY WAY RELATED TO PERFORMANCE, USE OR INABILITY TO USE ANY OF THE 3M PRODUCT.**

This limitation applies regardless of the legal theory upon which damages are sought. If 3M Product is defective within the applicable warranty period, your exclusive remedy shall be, at 3M's option, to replace or repair the 3M Product or to refund the purchase price of the 3M Product. All replaced parts or products become property of 3M. If the 3M Product is repaired, 3M will repair the defective part(s) with a new or used part(s). If the 3M Product is replaced, 3M will replace the product with the same or equivalent model and with a new or refurbished product. In the case of an approved warranty claim, the replacement 3M Product will carry only the remaining term of the original 3M Product's warranty period as stated in the applicable 3M Product Manual.

For warranty service, you must provide proof of the date of the original purchase, otherwise the manufacturing code date will be used to establish the start date of the warranty. 3M Product Manuals include durability statements and may include limitations specific to the product(s) being used or its intended applications, which take precedence over any statement made here. Warranty terms, limitations and exclusions may differ outside the United States of America.

### No Power

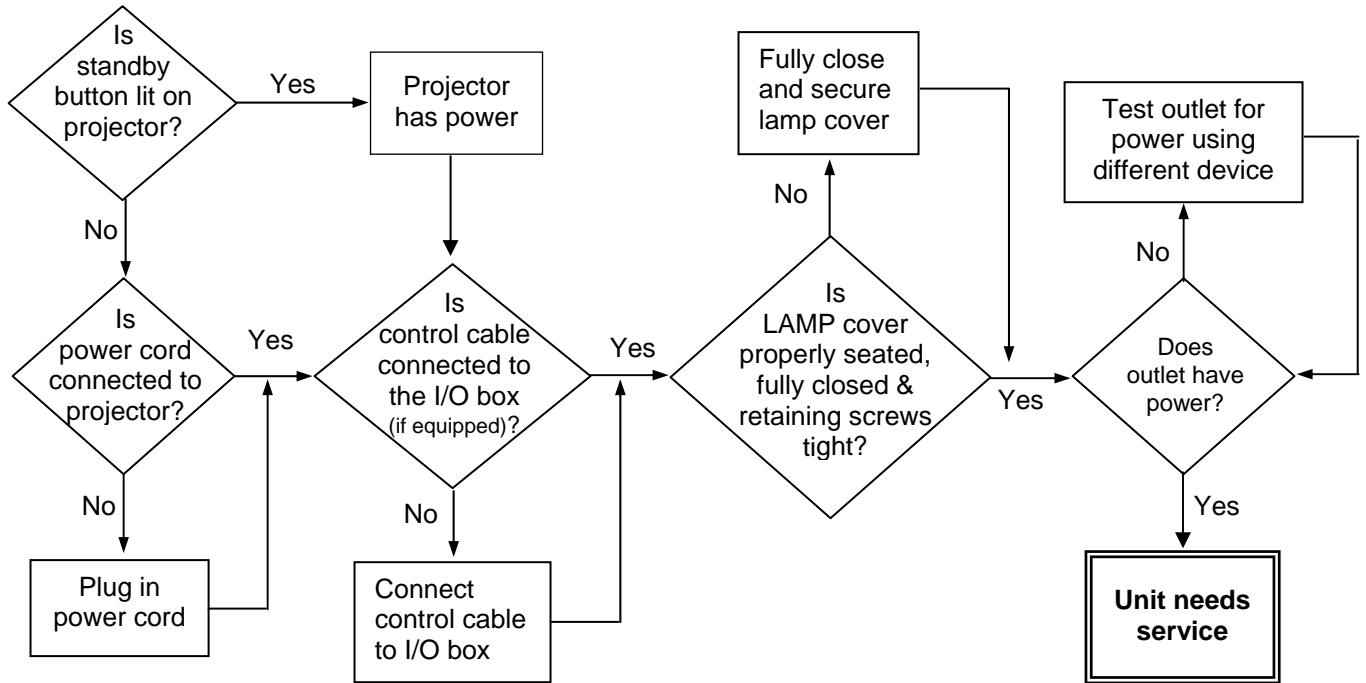

### Troubleshooting Comments:

### Lamp Will Not Ignite

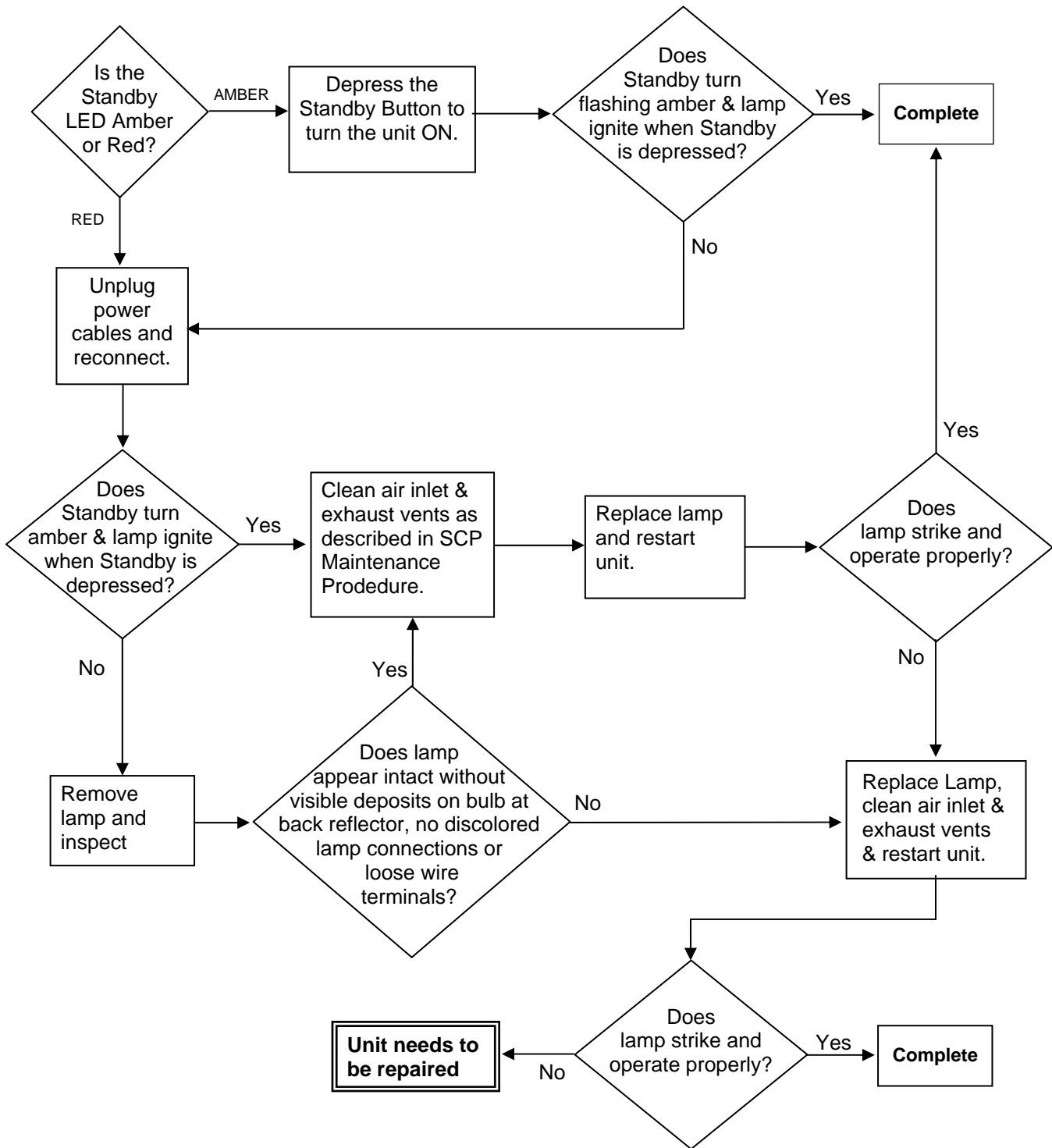

### Troubleshooting Comments:

### Lamp Will Not Remain Lit

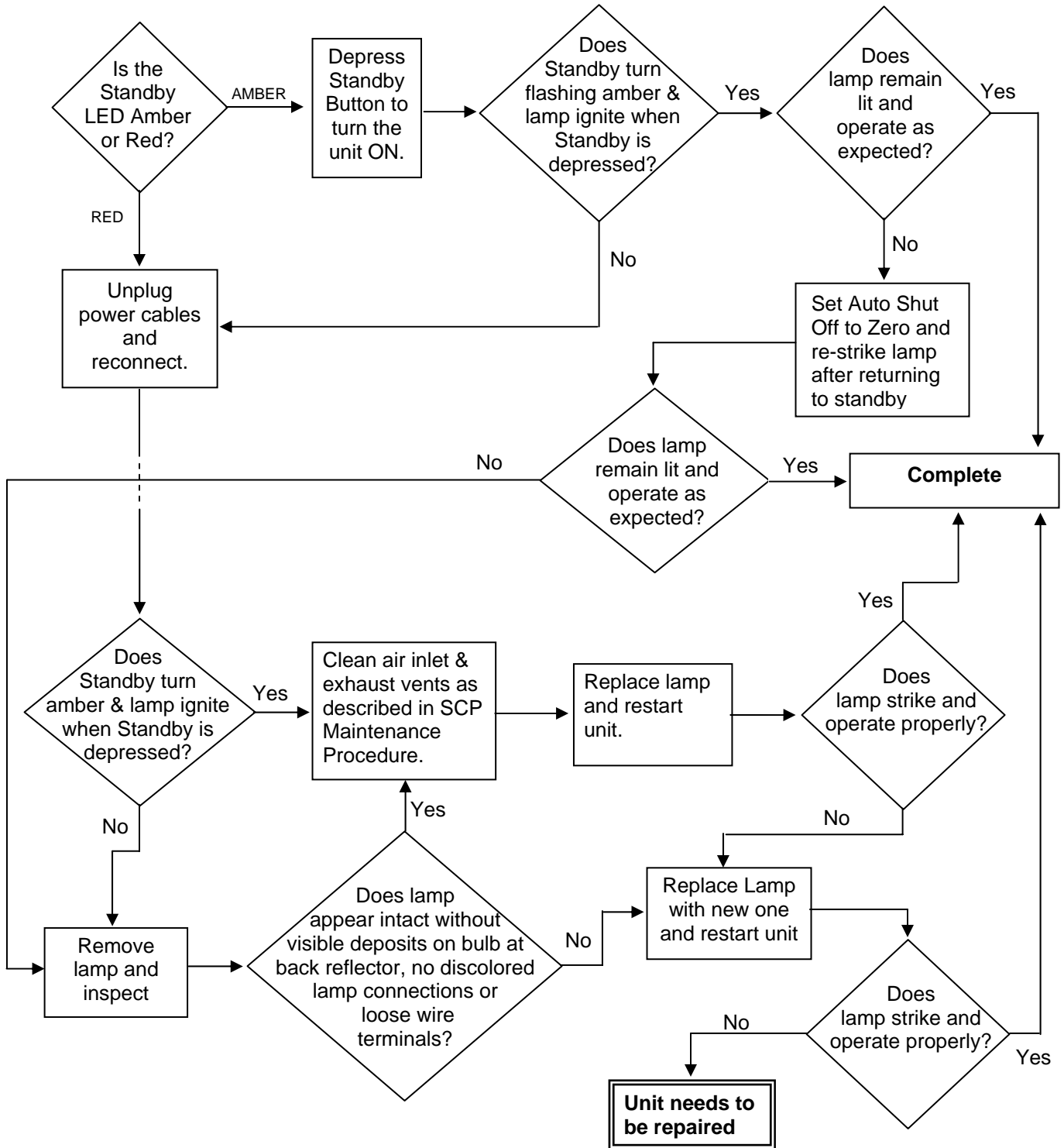

### Troubleshooting Comments:

**Poor Video Image  
(Composite or S-video)**

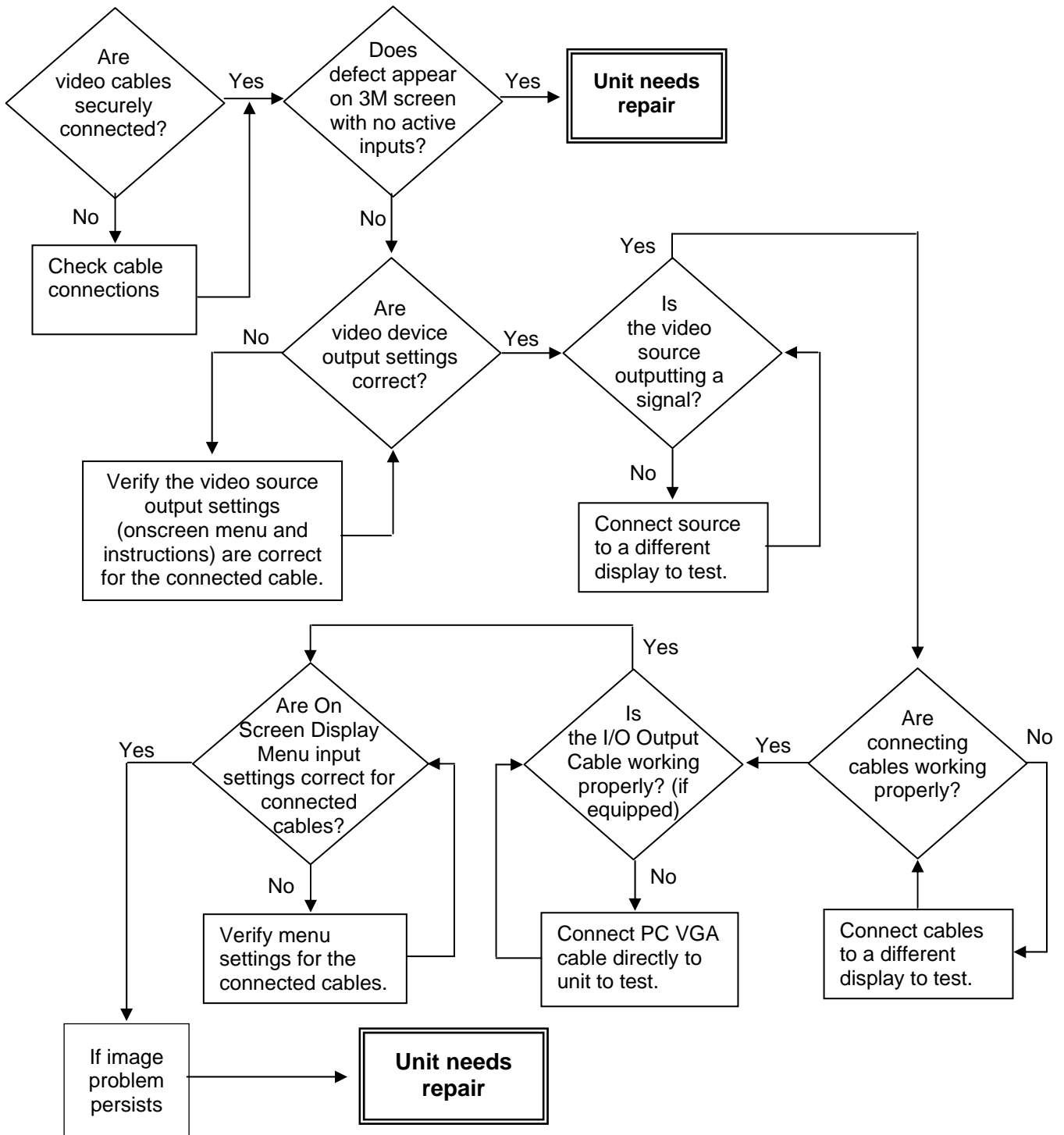

**Troubleshooting Comments:**

**Poor Graphical Image  
(VGA or Component)**

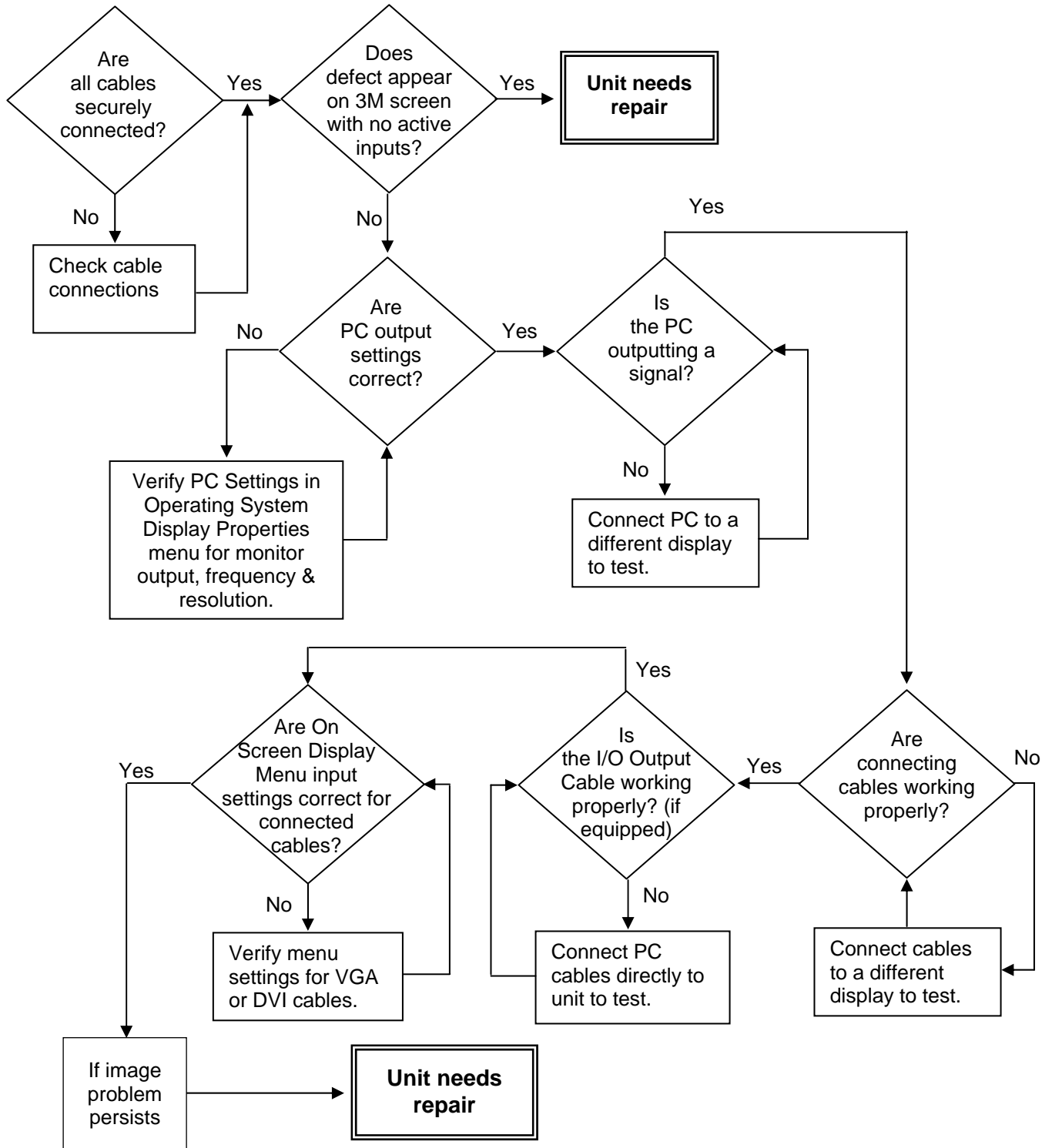

**Troubleshooting Comments:**

### Poor Sound

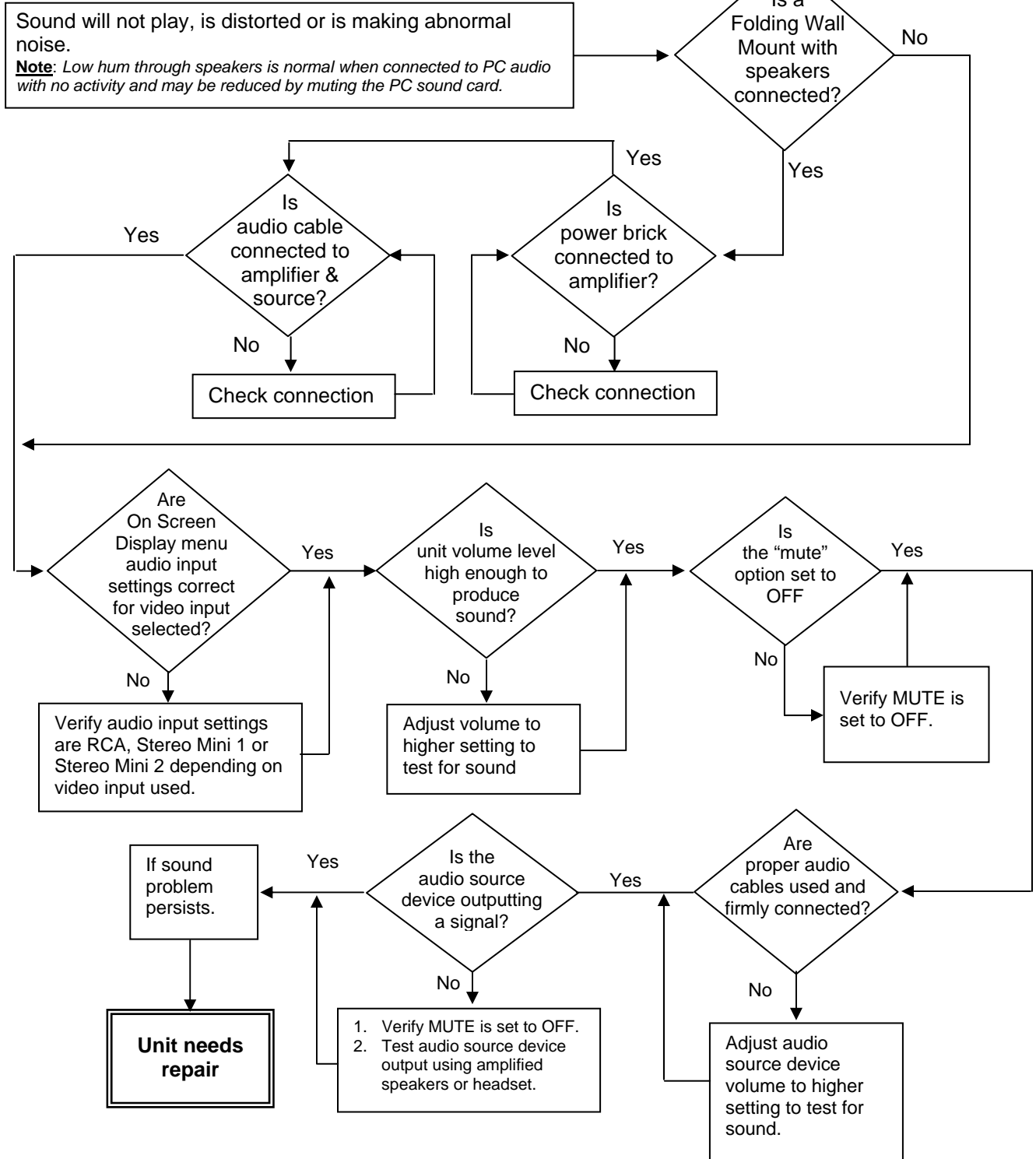

### Troubleshooting Comments:

## Digital Annotation Issues

**For updates on applicable Digital Annotation Issues, please review the DMS800 and SCP series FAQ's available at: [www.3m.com/meetings](http://www.3m.com/meetings). [Note: Select "Technical Documentation" then select "DMS800" or "SCP 712."]**

**-OR-**

**Contact our Call Center at 1-800-328-1371 for additional assistance.**



**800-328-1371**



**<http://www.3m.com/meetings>  
e-mail: [meetings@mmm.com](mailto:meetings@mmm.com)**